

SHAPES
FOR
ARCHITECTURE

GALASSIA
Italy

Creatività e innovazione sono i due concetti che meglio esprimono la capacità di Ceramica Galassia di distinguersi nel panorama nazionale e internazionale, come modello di riferimento di industria della ceramica sanitaria. A conferma di questa visione imprenditoriale, Galassia presenta un programma molto ampio sia di nuovi progetti sia di integrazioni alle collezioni esistenti.

I prodotti presentati, ispirati sempre più alle forme semplici, confermano il livello di qualità e maturazione raggiunto dall'azienda nei suoi 30 anni di attività.

Qualità dei processi produttivi, qualità e cura nella scelta dei materiali utilizzati sono un innegabile valore aggiunto che contribuisce a fare di Galassia una protagonista indiscussa del made in Italy.

Creativity and innovation are the two concepts that best express Galassia's capacity to stand out, in both national and international scene, as a reference model of the sanitary ware industry. Confirming this business vision, Galassia presents a very extensive program, for both the new projects and some additions to the existing collections.

The products at the show, more and more inspired to simple forms, confirm the quality level and maturity achieved by the company during thirty years of activity.

Quality of production processes, quality and care in the choice of the material used, are an undeniable added value which make Galassia be without any doubt a protagonist of the Made in Italy.

INDICE

CORE 46	39
TABULAE	51
MEG PRO	97
FOLIA	119
VASCHE / BATHTUB	
Quadra	140
Eden	144
Flow	148
WC - BIDET	
Dream	153
Meg Pro	169
Schede tecniche / Technical sheets	185



Creatività progettuale ed esperienza produttiva, insieme alla cultura industriale, fanno di Galassia un modello di riferimento dell'industria della ceramica sanitaria e del Made in Italy nel mondo. L'azienda opera nel distretto di Civita Castellana, centro rinomato per la tradizione ceramica, dove artigianalità, innovazione tecnologica e sostenibilità si fondono per offrire il meglio della qualità italiana.

Design creativity and production experience, along with industrial culture, make Galassia a reference model of Made in Italy ceramic industry in the world. The company is in Civita Castellana district, well known for the ceramic tradition, where craftsmanship, technological innovation and sustainability blend together to offer the best of Italian quality.



Galassia nasce nel 1980 nel distretto Ceramico di Civita Castellana ed oggi è azienda leader nella produzione italiana di sanitari in ceramica

Galassia SpA was born in 1980 in Civita Castellana ceramic district and today is leader company of sanitaryware Italian production



38 anni

75.000 m²

2 stabilimenti

Galassia si estende su una superficie di 75.000 M² di cui 40.000 coperti

Galassia has an area of 75.000 m² whose 40.000 are covered



La capacità produttiva è di 230.000 articoli annui

Production capacity is of 230.000 items per year

1 stabilimento produttivo sito in Corchiano (VT) e 1 logistico a Fabrica di Roma (VT)

1 production plant in Corchiano (VT) and 1 Logistic center in Fabrica di Roma (VT)



150 dipendenti

Attualmente Galassia occupa 150 dipendenti

At present 150 employees work for Galassia



I prodotti Galassia vengono distribuiti in oltre 75 paesi nel mondo

Galassia markets its products in over 75 countries around the world

75 paesi



500 prodotti

Ceramica Galassia offre un'ampia gamma di prodotti: lavabi, sanitari, vasche, piatti doccia, accessori, strutture e mobili

Ceramica Galassia offers a wide range of products: washbasins, sanitary wares, bathtubs, shower trays, accessories and furniture

La ceramica è un prodotto naturale, composto da materie prime quali caolino, quarzo e/o argilla.

I prodotti Galassia vengono realizzati in Fine Fire-clay e Vitreous China – materiali a ridotto impatto ambientale che per la loro composizione e produzione non utilizzano sostanze inquinanti. Galassia è leader indiscussa nella produzione italiana della Fine Fire-clay, risultato raggiunto in più di 30 anni di esperienza e attività nel settore.

Per la ceramica selezioniamo le migliori terre – in amalgama con l'acqua –, per ottenere un impasto di qualità:

ARGILLA

Favorisce la saldatura dei granuli che precede la fusione nel processo di cottura, determinando un aumento della resistenza, fornisce anche plasticità e lavorabilità all'impasto

CAOLINO

Aumenta la resistenza dell'impasto ad alte temperature, nonché il grado di bianco

FELDSPATO

Abbassa la temperatura di cottura, ha funzioni di fondente

CHAMOTTE

Aumenta le caratteristiche meccaniche e la refrattarietà

QUARZO

Aumenta il coefficiente di dilatazione termica e riduce la plasticità

Ceramic is a natural product, composed of a mix of raw materials such as kaolin, quartz and/or clay. The Galassia products are made of Fine Fire-clay and Vitreous China - materials with reduced environmental impact that do not use polluting substances due to their composition and production. Galassia is the undisputed leader in the Italian production of Fine Fire-clay, result achieved in more than 30 years of experience and activity in the sector.

For our ceramic we select the best raw materials - blended with water - to obtain a high quality mixture:

CLAY

It favors the welding of the granules before the fusion during firing process, determining a resistance increase. It also provides plasticity and workability to the slip

KAOLIN

It increases the mixture resistance at high temperature, as well as the glaze level

FELDSPAR

It decreases the firing temperature, it works as a fusion point

CHAMOTTE

It increases the mechanical characteristics and the refractoriness

QUARTZ

Increases the coefficient of thermal expansion and reduces plasticity





Galassia negli anni ha continuato a sviluppare una coscienza ecologica ed etica che l'ha portata a investire sulle fonti rinnovabili. Nell'affrontare tale tematica, ha contestualmente deciso di dotarsi di un impianto di autoproduzione di energia elettrica tramite l'utilizzo di un generatore fotovoltaico che sfrutta la superficie del tetto (7.000 m²).

Galassia has continued to develop an ecological and ethical conscience over the years which has led it to invest in renewable sources. In addressing this issue, at the same time it decided to equip itself with a self-generation system of electricity through the use of photovoltaic panels that exploit the roof surface of m² 7.000 .

7.000 m²



CO²

60° max



Le ultime collezioni sono state concepite ponendo particolare attenzione al risparmio idrico, attraverso il sistema di scarico dei WC – sia a terra che sospesi – che arriva ad utilizzare anche solo 3,5 litri di acqua, a fronte del precedente consumo di 7 lt.

The latest collections have been designed paying particular attention to water saving, through the toilet discharging system - both for wall hung and floor standing - which uses a 3,5 liter of water, compared to the previous consumption of 7 liters.

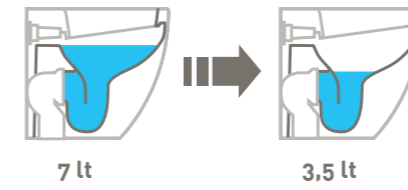

Gli smalti utilizzati si compongono di diversi elementi aventi differenti caratteristiche:

SILICATO DI ZINCONIO

Impedisce alla luce di penetrare e conferisce allo smalto il classico colore bianco

OSSIDO DI ZINCO

Abbassa la temperatura di fusione, la viscosità del fuso e migliora la brillantezza dello smalto

OSSIDO DI STAGNO

Opacizzante, migliora la qualità della superficie dello smalto e ne aumenta la brillantezza

DOLOMITE

Aumenta la tensione di superficie dello smalto fuso e ne regola il coefficiente di dilatazione

QUARZO

Controlla la durezza e la resistenza agli acidi dello smalto

Glazes used are composed by several elements having different features:

ZIRCONIUM SILICATE

It prevents light to penetrate and gives the glossy white to the glaze

ZINC OXIDE

It makes the melting temperature decreased, the viscosity and improves the brilliance of the glaze

PONDIOUS OXIDE

Matting material, it improves the glaze surface quality and increases its brilliance

DOLOMITE

It increases the surface tension of the molten glaze and regulates the expansion factor

QUARTZ

It controls the glaze hardness and acid resistance to the acids





Gli stampi in gesso, che plasmano la forma del prodotto, sono realizzati manualmente.

Plaster moulds, which shape the product, are manually made.

Nello stampo in gesso avviene la colatura del composto ceramico liquido. Il gesso dello stampo ha la funzione di assorbire l'acqua in eccesso e il composto ceramico, solidificandosi, dà forma al prodotto finito.

The slip is casted inside the plaster mould. The plaster mould absorbs the excess water and through the solidification of the ceramic compound, the finished product takes shape.







I prodotti, appena usciti dallo stampo, sono molto delicati. Nella fase successiva vengono controllati attentamente e poi rifiniti con una spugna a mano.

The products just taken out from the mould, are very fragile. In the next phase products are carefully checked and then finished with a sponge by hand.



Gli stampi in gesso sono controllati periodicamente e movimentati a mano. Dopo circa 80 prodotti colati, ogni stampo viene sostituito con uno nuovo.

Plaster moulds are checked periodically and they are hand moved. After 80 casted products each mould is replaced by new mould.

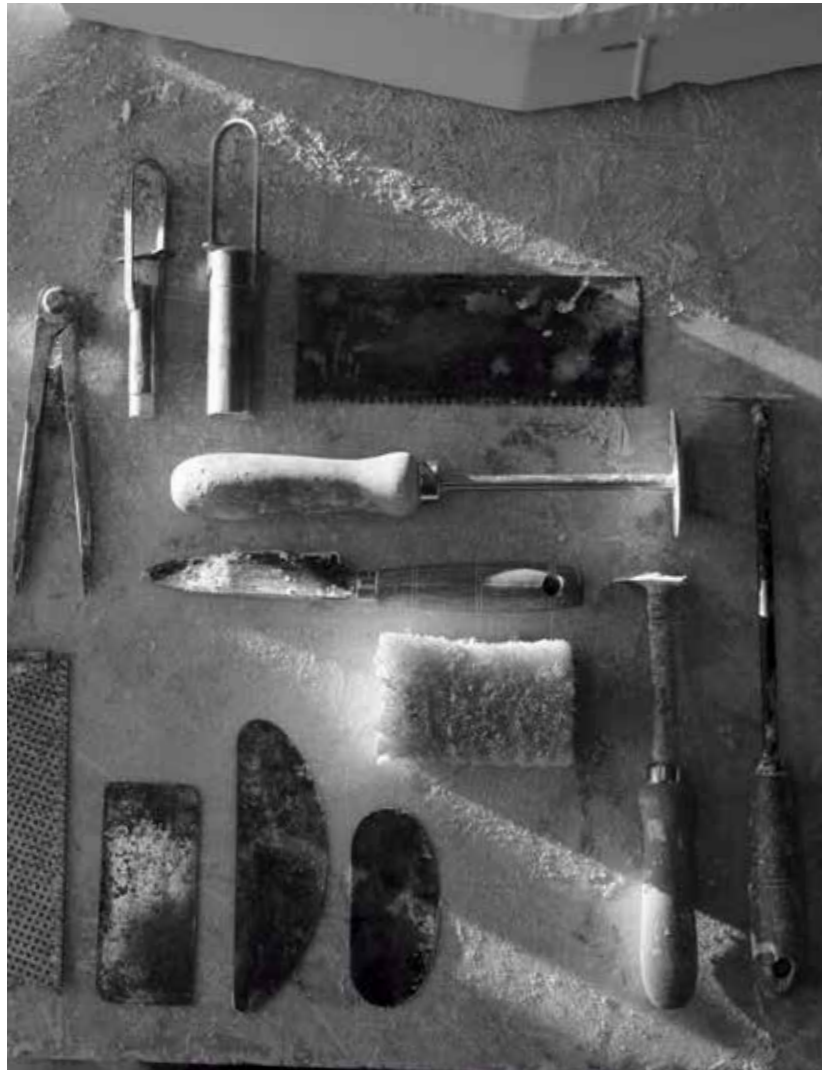

I semplici attrezzi che servono per la rifinitura manuale dei prodotti appena usciti dallo stampo.

The simple tools needed for the products finish as they come out of the mould.



La realizzazione dei prodotti in ceramica richiede molto lavoro manuale, abbinata a una grande abilità delle maestranze.

The production of ceramic products requires a lot of manual work, matched with a great workers' skill.



Il prodotto, una volta rifinito manualmente, viene smaltato. Galassia utilizza lo smalto Higerglaze che garantisce una superficie perfettamente liscia e facile da pulire. Dopo la smaltatura il lavabo viene cotto in forno per 24 ore.

The product, once handly finished, is glazed. Galassia uses Higerglaze which grants a perfect smooth surface, easy to clean. After glazing process, the washbasin is fired into the kiln for 24 hours.



Dopo la cottura, ogni pezzo viene controllato singolarmente. Ne viene testata e verificata la funzionalità prima della spedizione.

After firing, each single piece is checked. Some functional tests are carried out on products before shipping.



HIGHERGLAZE

Qualità superiore per l'innovativo smalto Higherglaze applicato sulla ceramica direttamente prima della cottura e utilizzato sia sui lavabi che sui sanitari. La superficie risulta essere perfettamente liscia non permettendo allo sporco e al calcare di depositarsi. Questo garantisce durevole brillantezza, piacevolezza al tatto, alta protezione da graffi, abrasioni e agenti esterni. L'estrema facilità di pulizia inoltre permette un minor consumo di acqua e detersivi nel rispetto dell'ambiente.

Superior quality for the innovative Higherglaze directly applied to the ceramic before firing process and used on both washbasins and sanitarywares. The surface is perfectly smooth and does not allow dirt and scale to settle. This guarantees lasting shine, pleasant touch, high protection against scratches, abrasions and external agents. The extreme ease of cleaning also allows a lower consumption of water and detergents in respect of the environment.



IDROREPELENTE

Idrorepellente: l'acqua scivola velocemente sulla superficie.

Water-repellent: water slides fast on the surface.



LEVIGATO

La superficie risulta essere perfettamente liscia.

The surface is perfectly smooth.



IGIENICO

Facilità e velocità di pulizia.

Easy and quick cleaning.



BRILLANTE

Maggiore brillantezza della superficie.

Greater surface brilliance.



GREEN CHALLENGE

GREEN

Sostenibilità ambientale: ridotto consumo di acqua e detersivi per la pulizia.

Environmental Sustainability: reduced water consumption and cleaning detergents.



DUREVOLE

Alta resistenza agli agenti esterni, maggior durevolezza nel tempo.

High resistance to external agents, longer durability.



RESISTENTE

Resistenza ad urti, graffi ed abrasioni.

Impact, scratch and abrasion resistance.

ATTIVITÀ ANTIBATTERICA
Antibacterial activity

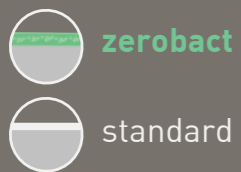
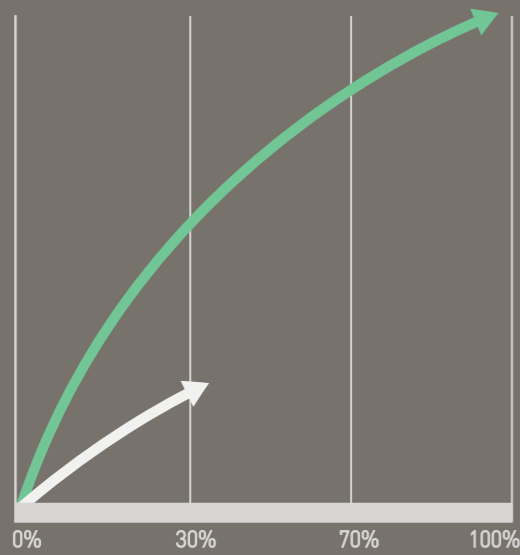
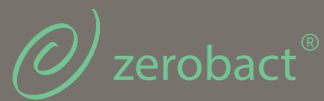

ZEROBACT®

L'innovativo smalto ZEROBACT® è una barriera totale contro germi e batteri. Viene integrato nello smalto e cotto con la ceramica ed è quindi in grado di garantire una protezione duratura e illimitata nel tempo. Questo smalto ha un'efficacia certificata pari al 99,9%. Certificazione ISO 22196: 2011.

Lo smalto ZEROBACT® viene fornito su richiesta.

The innovative ZEROBACT® glaze is a total barrier against germs and bacteria. It is integrated into the glaze and fired with the ceramics and grants a lasting and limitless protection over time. This glaze has an certified effectiveness equal to 99,9%. Iso 22196:2011 Certification.

ZEROBACT® glaze is supplied upon request.



I test di laboratorio hanno certificato secondo il metodo ISO 22196: 2011 un significativo abbattimento della carica batterica, pari al 99,9%.

ANTIBATTERICO

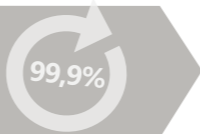

Laboratory tests certified according to ISO 22196: 2011 a significant reduction of bacterial load, equal to 99.9%.

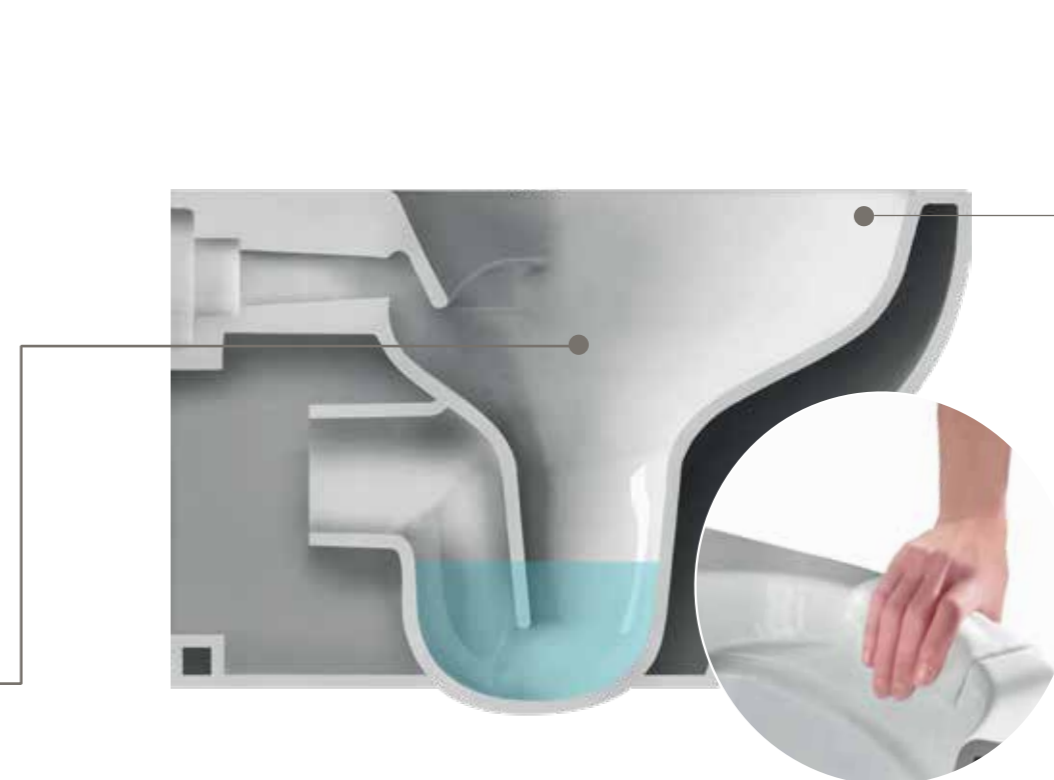

RIM AWAY

Nuovo sistema di scarico che permette una più rapida e accurata pulizia utilizzando solo 3,5 litri d'acqua per il risciacquo.

New drainage system which allows a more rapid and careful cleaning using only 3,5 liters of water for rinsing.



RESISTENTE



Resistente al calcare e ad urti e abrasioni.
Resistant to limestone, to impact and to abrasion.

DUREVOLE



Il processo integrato di cottura dello smalto assicura maggiore durevolezza nel tempo.
The integrated process of enamel firing ensures greater durability of the surfaces over time.

IGIENICO



Facilità e velocità di pulizia.
Easy and quick cleaning.

Gli smalti colorati, messi a punto da Galassia, mantengono invariato l'elevato standard di qualità e durevolezza degli smalti lucidi. Le nuove finiture si contraddistinguono per la raffinata superficie satinata piacevole al tatto. Le nuance proposte da Galassia ben si prestano a essere abbinate tra loro.

The color glazes, developed and created by Galassia, keep the high standard quality and durability of the glossy ones. The new finishes are distinguished by the refined satin surface pleasant to the touch. The nuances proposed by Galassia are well suited to be combined with each other.



MONOCOTTURA

Monocottura ad alta temperatura.
High temperature single firing.

RESISTENTE

Resistenza ad urti,
graffi ed abrasioni.
Impact, scratch and
abrasion resistance.



IGIENICO

Facilità e velocità
di pulizia.
Easy and quick
cleaning.



DUREVOLE

Alta resistenza agli agenti
esterni, maggior durevolezza
nel tempo.
High resistance to external
agents, longer durability.



COLORI ESCLUSIVI

Ampia gamma di colori abbinabili.
Wide range of matching colors.

Le finiture colorate sono ottenute tramite una monocottura ad alta temperatura **1250°**, a differenza degli standard tradizionali che realizzano le colorazioni in seconda cottura a temperature più basse.

Le nuove ed esclusive colorazioni proposte da Ceramica Galassia sono abbinate ad una selezione di lavabi, piatti doccia, wc e bidet.

The color finishes are obtained through a high temperature **1250°** single firing, different from the traditional process which applies the color in second firing at a lower temperature.

The new and exclusive colors proposed by Ceramica Galassia are combined with a selection of washbasins, shower trays, toilets and bidets.

RESISTENZA E DUREVOLEZZA
/ resistance & durability

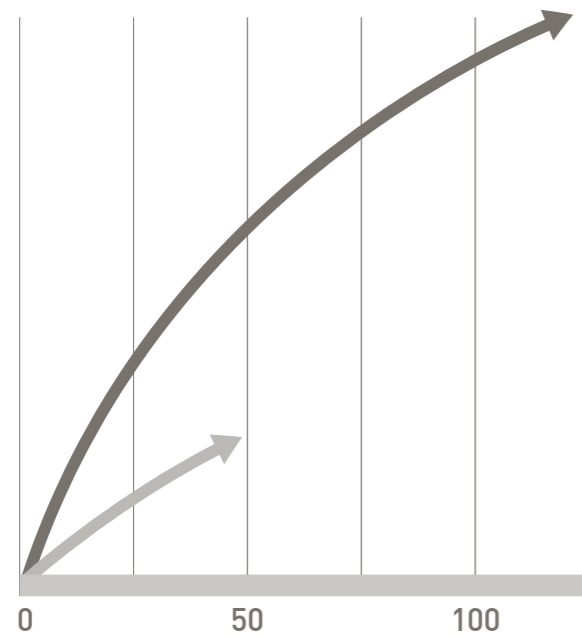

SMALTO GALASSIA **1250°**

realizzato in monocottura ad alte temperature
/ made in high temperature single firing process



SMALTO STANDARD **850°**

realizzato in seconda cottura a temperature più basse
/ made in second firing at a lower temperature

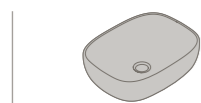

lavabi
washbasin

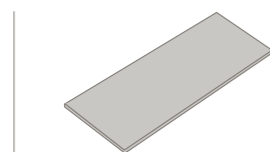

mensole Tabulae
shelves

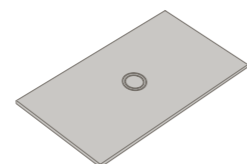

piatti doccia
shower trays

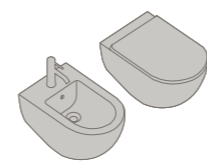

sanitari
sanitaryware



bianco
/ white



nero
/ black



ottanio
/ petrol blue



sabbia
/ sand



CORE 46



CORE 46

LAVABO APPOGGIO / SOSPESO
/ Countertop - Wall hung washbasin

Con staffa di fissaggio
realizzata in acciaio satinato.

With satin stainless steel
fixing bracket.

COLORI / Colors

-  bianco / white
-  bianco mat / matt white
-  nero mat / matt black
-  sabbia / sand
-  ottanio / petrol blue



CORE 46

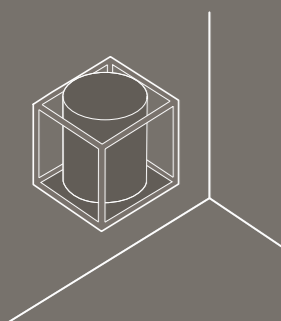

STRUTTURA IN ACCIAIO
/ Steel structure

Struttura realizzata in acciaio
verniciato nero opaco.

Steel structure varnished in
matt black finish.

CORE 46







TABULAE





TABULAE

combinazioni di colore
/ color combination

lavabo Dream
/ washbasin
50 x 38 cm
64 x 38 cm



lavabo Smart B
/ washbasin
55 x 38 cm
65 x 38 cm

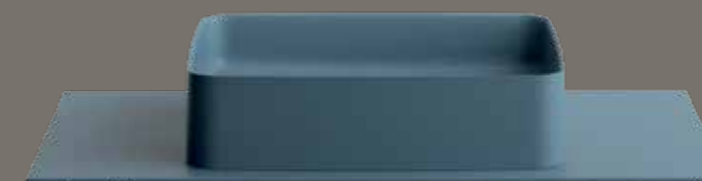

WC - BIDET



52_{cm}

WC SOSPESO
Wall-hung wc

Art.		Kg	Pz.pallet	Ind.Price
8971	bianco white	22,7	15	60900.00
8971MT	bianco matt matt white	22,7	15	81200.00
8971NE	nero lucido glossy black	22,7	15	85550.00

Wc sospeso 52x38x25 cm.
Wall-hung wc 52x38x25 cm.

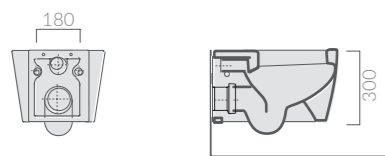
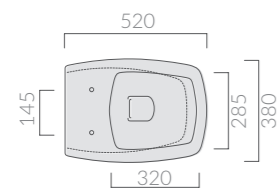

COPRIVASO SOFT CLOSE
Soft-close seat-cover

Art.		Kg	Pz.pallet	Ind.Price
8977	bianco white	2,8		25665.00
8977NE	nero lucido glossy black	2,8		27550.00

Coprivaso avvolgente in termoindurente, cerniera con dispositivo di caduta rallentata e sganciamento rapido.
Thermosetting wrap around seat-cover with soft closing system and quick release system.



55_{cm}

WC SOSPESO
Wall-hung wc

Art.		Kg	Pz.pallet	Ind.Price
5486	bianco white	23	15	53650.00
5486MT	bianco matt matt white	23	15	72355.00
5486NE	nero lucido glossy black	23	15	80475.00
5486NEMT	nero matt matt black	23	15	80475.00
5486GM	grigio matt matt grey	23	15	80475.00
5486SA	sabbia sand	23	15	80475.00

Wc sospeso SENZA BRIDA 55x35 cm. Fissaggio incluso.
Wall-hung wc WITHOUT RIM 55x35 cm. Fixing kit included.

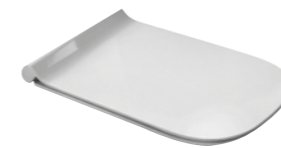
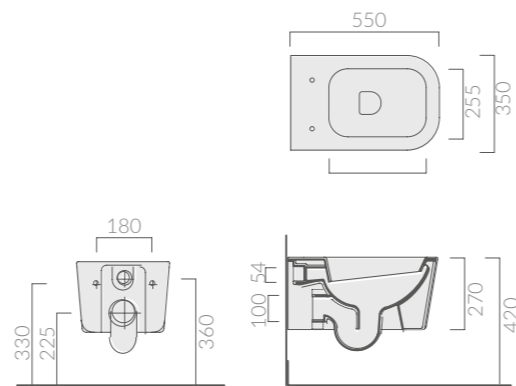

COPRIVASO EXTRA SLIM SOFT CLOSE
Soft close extra slim seat-cover

Art.		Kg	Pz.pallet	Ind.Price
5478	bianco white	2		18125.00
5478MT	bianco matt matt white	2		25375.00
5478NE	nero lucido glossy black	5		34075.00
* 5478NEMT	nero matt matt black	2		34075.00
* 5478GM	grigio matt matt grey	2		34075.00
* 5478SA	sabbia sand	5		34075.00

Coprivaso termoindurente extra slim, cerniera con dispositivo di caduta rallentata. Dispositivo di sgancio rapido.
Thermosetting extra slim seat-cover, with soft closing hinges and quick release system.



55_{cm}

WC SOSPESO
Wall-hung wc

Art.		Kg	Pz.pallet	Ind.Price
6111	bianco white	28	15	47850.00

Wc sospeso 55x36 cm.
Wall-hung wc 55x36 cm.

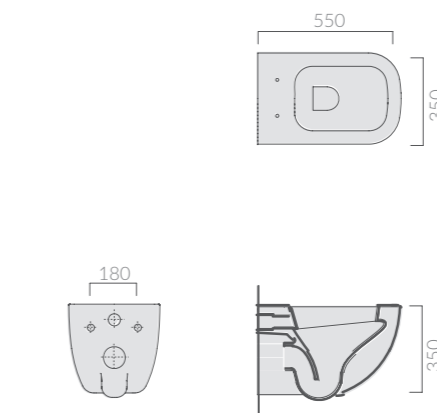

WC - BIDET

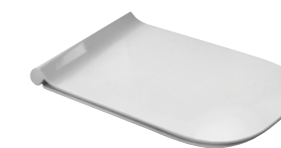

COPRIVASO EXTRA SLIM SOFT CLOSE
Soft close extra slim seat-cover

Art.		Kg	Pz.pallet	Ind.Price
5478	bianco white	2		18125.00
5478MT	bianco matt matt white	2		25375.00
5478NE	nero lucido glossy black	5		34075.00
* 5478NEMT	nero matt matt black	2		34075.00
* 5478GM	grigio matt matt grey	2		34075.00
* 5478SA	sabbia sand	5		34075.00

Coprivaso termoindurente extra slim, cerniera con dispositivo di caduta rallentata. Dispositivo di sgancio rapido.
Thermosetting extra slim seat-cover, with soft closing hinges and quick release system.

WC - BIDET



56_{cm}

WC SOSPESO
Wall-hung wc

Art.		Kg	Pz.pallet	Ind.Price
7317	bianco white	21,5	15	47850.00
7317MT	bianco matt matt white	21,5	15	64525.00
* 7317NEMT	nero matt matt black	21,5	15	71775.00
* 7317GM	grigio matt matt grey	21,5	15	71775.00

Wc sospeso SENZA BRIDA 56x36 cm.
Without RIM wall-hung wc 56x36 cm.

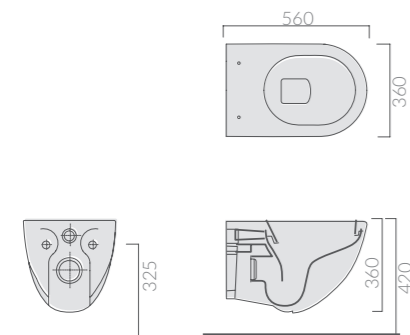

COPRIVASO EXTRA SLIM SOFT CLOSE
Soft-close extra slim seat-cover

Art.		Kg	Pz.pallet	Ind.Price
7314	bianco white	2,1		18705.00
7314MT	bianco matt matt white	2,1		26100.00
* 7314NEMT	nero matt matt black	2,1		34075.00
* 7314GM	grigio matt matt grey	2,1		34075.00

Coprivaso termoindurente extra slim, cerniera con dispositivo di caduta rallentata. Dispositivo di sgancio rapido.
Thermosetting extra slim seat-cover, with soft closing hinges and quick release system.



50_{cm}

WC SOSPESO
Wall-hung wc

Art.		Kg	Pz.pallet	Ind.Price
5218	bianco white	22	15	31320.00

Wc sospeso 50x35xh34,5 cm.
Wall-hung wc 50x35xh34,5 cm.

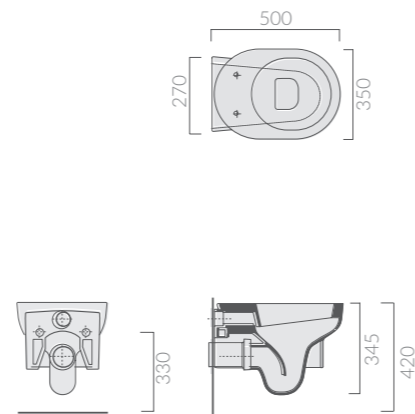

COPRIVASO SOFT CLOSE
Soft-close seat-cover

Art.		Kg	Pz.pallet	Ind.Price
5224	bianco white	2,3		15515.00

Coprivaso avvolgente in termoindurente, cerniera con dispositivo di caduta rallentata.
Thermosetting wrap around seat-cover with soft closing system.



53_{cm}

WC SOSPESO SENZA BRIDA
Wall-hung wc WITHOUT RIM

Art.		Kg	Pz.pallet	Ind.Price
7212	bianco white	24	18	25955.00

Wc sospeso SENZA BRIDA 53x36xh33 cm.
Fissaggio incluso.
Wall-hung wc, WITHOUT RIM 53x36xh33 cm.
Fixing kit included.

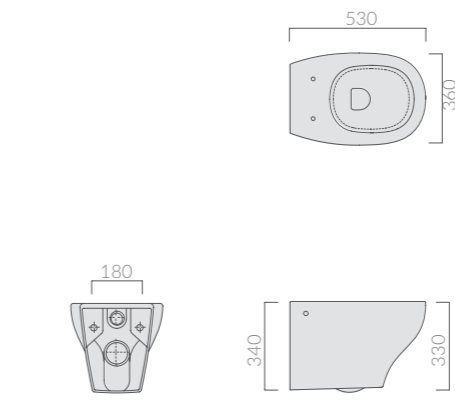

COPRIVASO AVVOLGENTE SOFT CLOSE
Soft close seat-cover

Art.		Kg	Pz.pallet	Ind.Price
7220	bianco white	2,2		14645.00

Coprivaso avvolgente in termoindurente, cerniera con dispositivo di caduta rallentata.
Thermosetting wrap around seat-cover with soft closing system.



75_{cm}

LAVABO
Washbasin

Art.		Kg	Pz.pallet	Ind.Price
7408	bianco white	16	18	60175.00
7408MT	bianco matt matt white	16	18	81200.00
7408NEMT	nero matt matt black	16	18	94975.00
7408GM	grigio matt matt grey	16	18	94975.00
7408ON	ottanio petrol blue	16	18	94975.00
7408SA	sabbia sand	16	18	94975.00

Lavabo da appoggio con piano rubinetteria 75x45 cm.
Countertop washbasin with tap counter 75x45 cm.

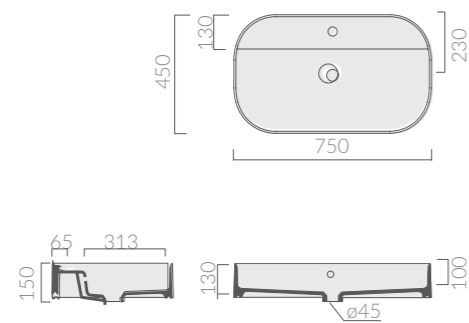

65_{cm}

LAVABO
Washbasin

Art.		Kg	Pz.pallet	Ind.Price
7407	bianco white	11	18	55100.00
7407MT	bianco matt matt white	11	18	74675.00
7407NEMT	nero matt matt black	11	18	87725.00
7407GM	grigio matt matt grey	11	18	87725.00
7407ON	ottanio petrol blue	11	18	87725.00
7407SA	sabbia sand	11	18	87725.00

Lavabo da appoggio senza piano rubinetteria 65x38 cm.
Countertop washbasin without tap counter 65x38 cm.

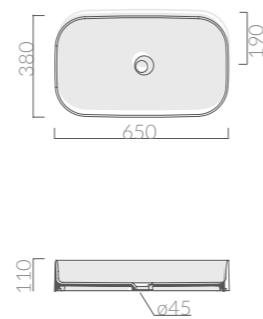

65_{cm}

LAVABO SMART B
Washbasin

Art.		Kg	Pz.pallet	Ind.Price
7415	bianco white	11	18	60900.00
7415MT	bianco matt matt white	11	18	81925.00
7415NEMT	nero matt matt black	11	18	96425.00
7415GM	grigio matt matt grey	11	18	96425.00
7415ON	ottanio petrol blue	11	18	96425.00
7415SA	sabbia sand	11	18	96425.00

Lavabo da appoggio cm 65 x 38. Senza foro troppo pieno.
Countertop washbasin 65 x 38 cm without overflow.

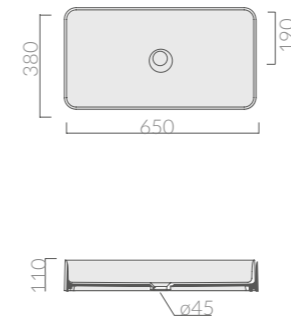

55_{cm}

LAVABO
Washbasin

Art.		Kg	Pz.pallet	Ind.Price
6103	bianco white	12	30	44225.00

Lavabo cm 55x38xh12. Installazione in appoggio.
Washbasin 55x38xh12 cm. Laid-on installation.

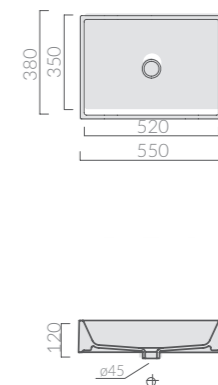



121_{cm}

LAVABO
Washbasin

Art.		Kg	Pz.pallet	Ind.Price
8938	bianco white	19	16	84100.00
8938MT	bianco matt matt white	19	16	113100.00

Lavabo cm 121 x 46 monoforo con troppo pieno. Installazione sospesa
Washbasin 121 x 46 cm 1 tap hole with overflow. Wall-hung installation.

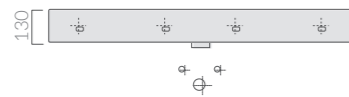
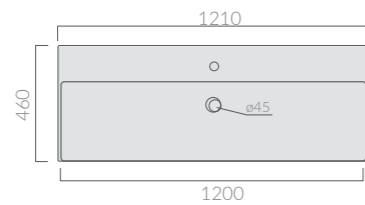

101_{cm}

LAVABO
Washbasin

Art.		Kg	Pz.pallet	Ind.Price
8937	bianco white	19	16	73950.00
8937MT	bianco matt matt white	19	16	100050.00

Lavabo cm 101 x 46 monoforo con troppo pieno. Installazione sospesa
Washbasin 101 x 46 cm 1 tap hole with overflow. Wall-hung installation.

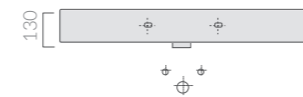
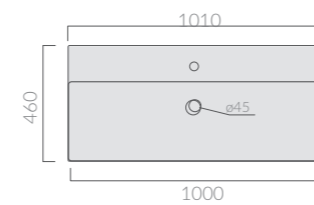

71_{cm}

LAVABO
Washbasin

Art.		Kg	Pz.pallet	Ind.Price
8968	bianco white	19		49300.00
8968MT	bianco matt matt white	19		66700.00

Lavabo cm 71 x 46 monoforo con troppo pieno. Installazione sospesa
Washbasin 71 x 46 cm 1 tap hole with overflow. Wall-hung installation.

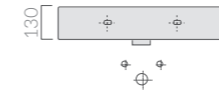
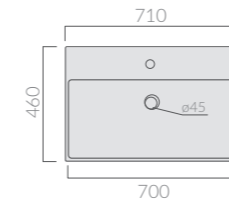

65_{cm}

LAVABO
Washbasin

Art.		Kg	Pz.pallet	Ind.Price
7400	bianco white	14	16	55100.00
7400MT	bianco matt matt white	14	16	74675.00
7400NEMT	nero matt matt black	14	16	87725.00
7400GM	grigio matt matt grey	14	16	87725.00
7400ON	ottanio petrol blue	14	16	87725.00
7400SA	sabbia sand	14	16	87725.00

Lavabo da appoggio con piano rubinetteria 65x45 cm.
Countertop washbasin with tap counter 65x45 cm.

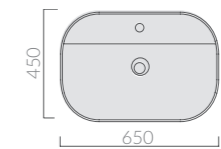



MENSOLA IN CERAMICA CON FORO CENTRALE
Ceramic shelf with central hole
101 cm

Art.		Kg	Pz.pallet	Ind.Price
2052	bianco white	22		52200.00
2052MT	bianco matt matt white	22		65250.00
2052NEMT	nero matt matt black	22		65250.00
2052ON	ottanio petrol blue	22		65250.00
2052SA	sabbia sand	22		65250.00

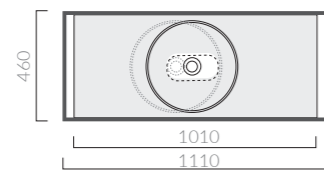

ø38cm

LAVABO SMART B
Washbasin

Art.		Kg	Pz.pallet	Ind.Price
7405	bianco white	6	36	46400.00
7405MT	bianco matt matt white	6	36	62350.00
7405NEMT	nero matt matt black	6	36	74675.00
7405GM	grigio matt matt grey	6	36	74675.00
7405ON	ottanio petrol blue	6	36	74675.00
7405SA	sabbia sand	6	36	74675.00

Lavabo da appoggio cm ø38. Senza foro troppo pieno.
Countertop washbasin ø38 cm without overflow.

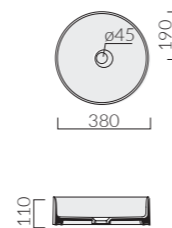

64cm

LAVABO DREAM
Washbasin

Art.		Kg	Pz.pallet	Ind.Price
7300	bianco white	16	18	46110.00
7300MT	bianco matt matt white	16	18	62350.00
7300NEMT	nero matt matt black	16	18	68875.00
7300GM	grigio matt matt grey	16	18	68875.00
7300ON	ottanio petrol blue	16	18	68875.00
7300SA	sabbia sand	16	18	68875.00

Lavabo da appoggio cm 64 x 38. Senza foro troppo pieno.
Countertop washbasin 64 x 38. Without overflow.

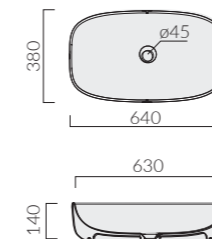

50cm

LAVABO DREAM
Washbasin

Art.		Kg	Pz.pallet	Ind.Price
7301	bianco white	11	30	41470.00
7301MT	bianco matt matt white	11	30	55970.00
7301NEMT	nero matt matt black	11	30	62350.00
7301GM	grigio matt matt grey	11	30	62350.00
7301ON	ottanio petrol blue	11	30	62350.00
7301SA	sabbia sand	11	30	62350.00

Lavabo da appoggio cm 50 x 38. Senza foro troppo pieno.
Countertop washbasin 50x38 cm. Without overflow.

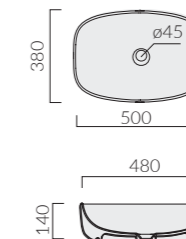



60_{cm}

LAVABO
Washbasin

Art.		Kg	Pz.pallet	Ind.Price
7304	bianco white	31	5	218950.00
7304MT	bianco matt matt white	31	5	295800.00

Lavabo da appoggio 50x38 cm. Senza foro troppo pieno.
Countertop washbasin 50x38. Without overflow.

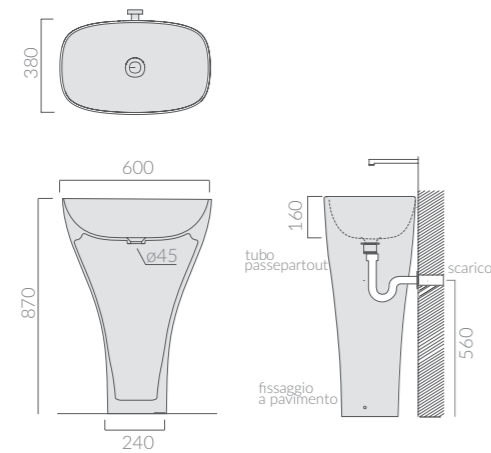

60_{cm}

LAVABO
Washbasin

Art.		Kg	Pz.pallet	Ind.Price
7106	bianco white	9	20	45820.00
7106MT	bianco matt matt white	9	20	62060.00

Lavabo da appoggio 60x36xh16 cm.
Senza foro troppopieno. Completo di piletta in ceramica a scarico libero.
Countertop washbasin 60x36xh16 cm.
Without overflow. Completed with ceramic free discharge waste.

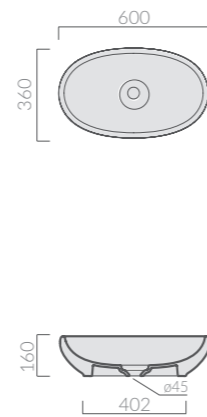

Ø40_{cm}

LAVABO
Washbasin

Art.		Kg	Pz.pallet	Ind.Price
7104	bianco white	15	12	56260.00
7104MT	bianco matt matt white	15	12	75980.00

Lavabo da appoggio Ø 40 cm. Senza foro troppopieno.
H44 cm. Completo di piletta in ceramica a scarico libero. Completo di tubo di scarico.
Countertop washbasin Ø 40 cm. Without overflow.
H44 cm. Completed with ceramic free discharge waste. Drain pipe included.

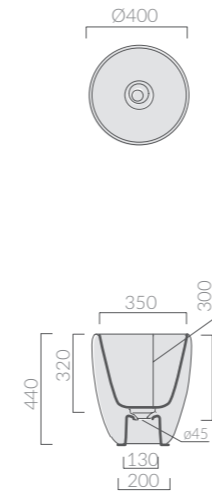

Ø42_{cm}

LAVABO
Washbasin

Art.		Kg	Pz.pallet	Ind.Price
7148	iroko iroko	20	12	240700.00

Lavabo da appoggio Ø 40 cm in legno massello di iroko. Senza foro troppopieno. Completo di tubo di scarico.
Countertop washbasin Ø 40 cm in iroko solid wood. Without overflow drain pipe included.

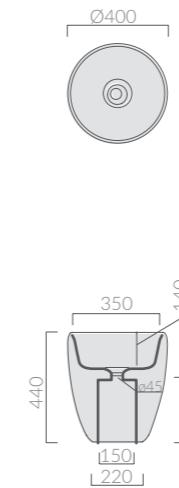

98_{cm}

MENSOLA SOSPESA
Wall hung shelf

Art.		Kg	Pz.pallet	Ind.Price
7322	corten corten	17		95990.00

Mensola portalavabo cm 98 in acciaio ossidato chimicamente, finitura corten. Completa di staffe di fissaggio.
Chemically oxidized steel shelf cm 98, corten finish. Fixing kit included.

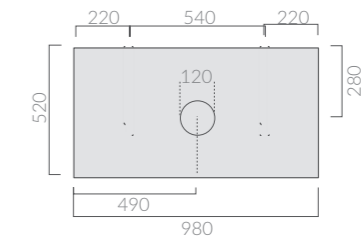



105_{cm}

LAVABO
Washbasin

Art.		Kg	Pz.pallet	Ind.Price
7103	bianco white	26	8	50750.00

Lavabo cm 105x45, monoforo. Installazione sospesa/soprapiano. Fissaggio incluso.
Washbasin 105x45 cm, one hole. Wall-hung/ countertop installation. Fixing kit included.

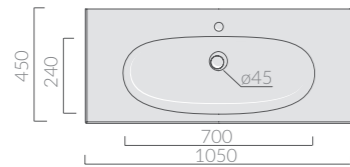

105_{cm}

STRUTTURA
Structure

Art.		Kg	Pz.pallet	Ind.Price
7156	iroko iroko	7		205610.00

Struttura in legno massello di iroko 105x45xh83 cm.
Structure in iroko heartwood cm 105x45xh83.

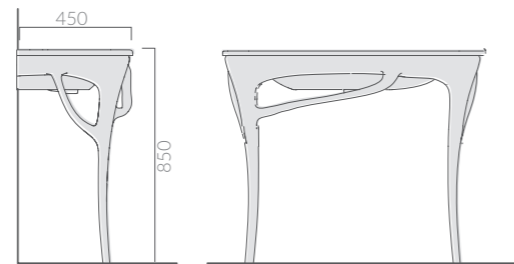

32_{cm}

ORINATOIO SOSPESO
Wall hung urinal

Art.		Kg	Pz.pallet	Ind.Price
5408	bianco white	16		48865.00

Orinatoio sospeso. Completo di erogatore e fissaggio.
Wall mounted urinal with dispenser and fixing kit.

PILETTA CON GRIGLIA PER ORINATOIO
Outlet drain with grate for urinal

Art.		Kg	Pz.pallet	Ind.Price
6069		1		4495.00

Piletta con griglia per orinatoio.
Outlet drain with grate for urinal.

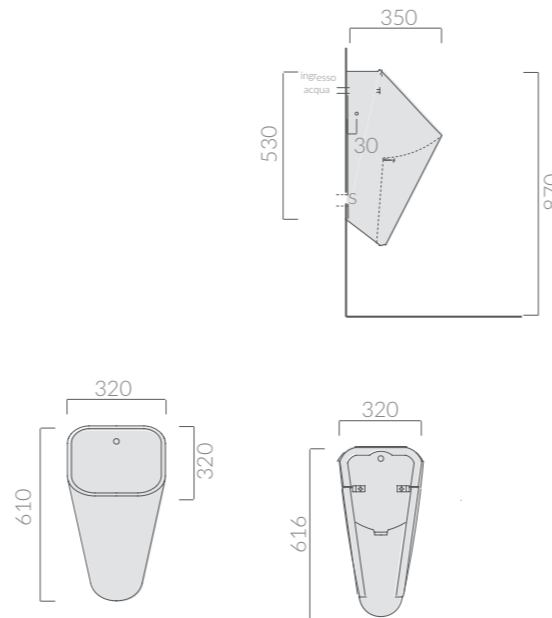

65_{cm}

LAVABO - LAVATOIO
Washbasin - washtub

Art.		Kg	Pz.pallet	Ind.Price
5403	bianco white	32	6	48140.00
5403MT	bianco matt matt white	32	6	64960.00

Kit di fissaggio incluso.
Wall-hung washbasin-washtub 65x45 cm, wall tap.
Fixing kit included.

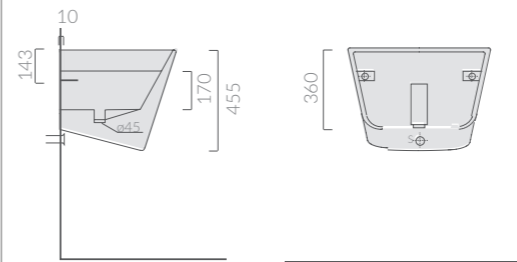

ASSE IN LEGNO
Wooden Board

Art.		Kg	Pz.pallet	Ind.Price
5442			2	30160.00

Asse in legno di okoumè per lavabo art. 5403
Okoumè wooden board for washbasin art. 5403.

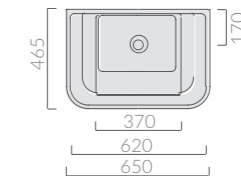



64
LAVABO
Washbasin

Art.	Kg	Pz.pallet	Ind.Price
6071	15	15	71775.00

Lavabo ovale da appoggio/incasso 64x42 cm. Piletta in ottone a corredo.
Laid-on/recessed oval washbasin 64x42 cm. Complete with brass drain.

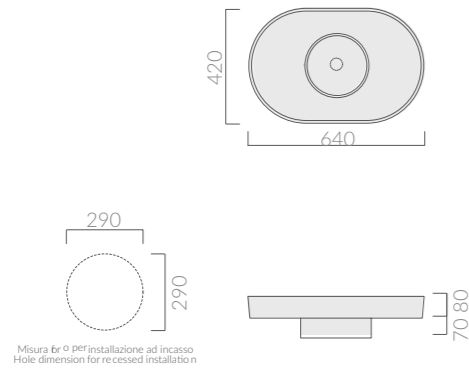

Ø42
LAVABO
Washbasin

Art.	Kg	Pz.pallet	Ind.Price
6070	12	15	63510.00

Lavabo tondo da appoggio/incasso Ø42 cm. Piletta in ottone a corredo.
Laid-on/recessed round washbasin Ø42 cm. Complete with brass drain.

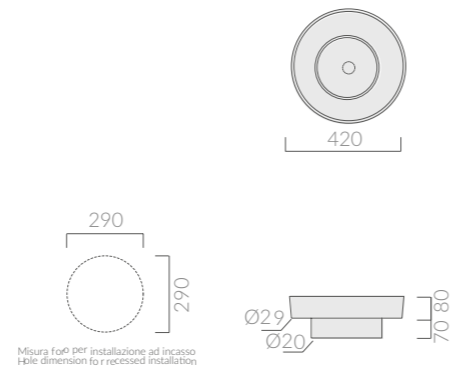

Ø37

LAVABO CORE
Washbasin

Art.	Kg	Pz.pallet	Ind.Price
7305	21	8	71050.00
7305MT	21	8	92365.00
7305NEMT	21	8	92365.00
7305ON	21	8	92365.00
7305SA	21	8	92365.00

Lavabo da appoggio cm Ø37 con piletta in ceramica e sifone inclusi. Senza foro troppo pieno.
Countertop washbasin Ø37cm with ceramic cover, click clack drain and siphon included. Without overflow.

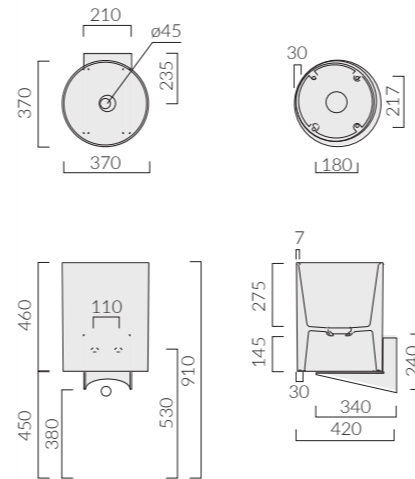

STAFFA PER LAVABO SOSPESO
Washbasin bracket for wall hung installation

Art.	Kg	Pz.pallet	Ind.Price
2082	3		50460.00

Staffa per installazione a parete, realizzata in acciaio satinato.
Bracket for wall hung installation, realized in satin stainless steel.

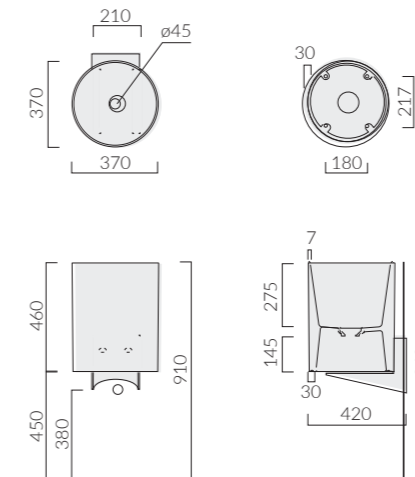

46cm
STRUTTURA SOSPESA
Wall mounted structure

Art.	Kg	Pz.pallet	Ind.Price
2081NE			72500.00

Struttura sospesa con piano in metallo cm 46 x 46 in acciaio / finitura nero opaco.
Wall mounted stainless steel structure with metal shelf included cm 46 x 46 / black finishing.

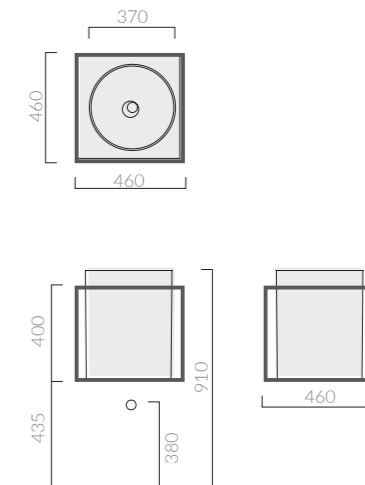



56
DREAM WC
Dream wc

Art.		Kg	Pz.pallet	Ind.Price
7310		31	15	46400.00
7310MT	bianco mat white matt	31	15	62640.00

Wc con scarico universale S/P 56x36 cm, trasfor-
mabile tramite curva tecnica. Fissaggio incluso.
W.c. with floor/wall draining 56x36 cm, adjustable
by elbow/wall pipe. Fixing kit included.

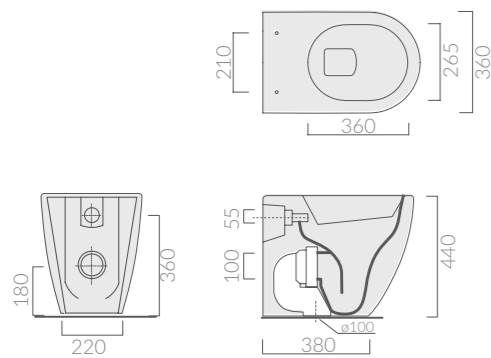

COPRIVASO MULTIFUNZIONE
Multifunction seat-cover

Art.		Kg	Pz.pallet	Ind.Price
7319		5		191400.00

Coprivaso elettronico multifunzione, in materiale
plastico antibatterico, con dispositivo di caduta
rallentata e telecomando a sfioramento.
Germ-resistant plastic seat cover, multifunction, with
soft closing system and soft touch remote control.



51^{cm}
WC SOSPESO
Wall-hung wc

Art.		Kg	Pz.pallet	Ind.Price
9907	bianco white	22	12	52200.00
9907NE	nero lucido glossy black	22	12	75400.00
9907PL	platino/bianco platinum/white	22	12	90190.00

Wc sospeso 51x38xh30 cm.
Wall-hung wc 51x38xh30 cm.

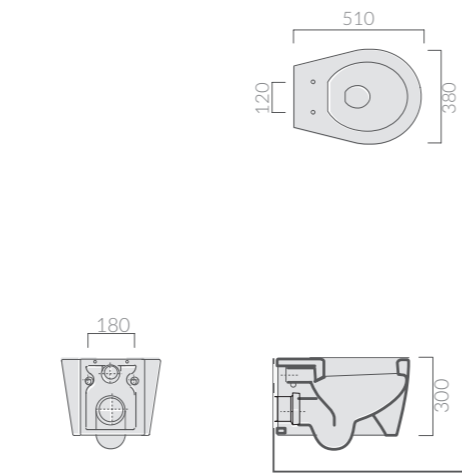

COPRIVASO
Seat-cover

Art.		Kg	Pz.pallet	Ind.Price
9920	bianco white	2,6		11600.00
9920NE	nero lucido glossy black	2,6		31030.00

Coprivaso avvolgente in termoindurente.
Thermosetting wrap around seat-cover.



70^{cm}
LAVABO
Washbasin

Art.		Kg	Pz.pallet	Ind.Price
5234	bianco white	12,5	18	43355.00
5234OR	oro/bianco gold/white	12,5	18	95120.00
5234PL	platino/bianco platinum/white	12,5	18	95120.00
5234NO	oro/nero gold/black	12,5	18	103965.00
5234NE	nero lucido glossy black	12,5	18	63075.00

Lavabo ciotola cm 70x37xh15. Per rubinetteria a
parete o su piano. Installazione da appoggio.
Washbasin 70x37xh15 cm. Arranged for wall tap or
on a countertop. Laid-on installation.

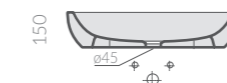
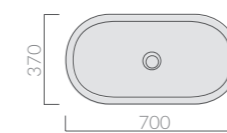

70^{cm}
STRUTTURA/
Structure for basin

Art.		Kg	Pz.pallet	Ind.Price
5550BB	bianco white	21		182555.00
5550BNE	nero lucido glossy black	21		182555.00

Struttura portalavabo in resina, laccata lucida con
basamento in metallo. Completo di fissaggio per
lavabo e kit di scarico dell'acqua. Abbinabile al
lavabo art. 5234 (bianco e nelle finiture colorate).

Structure for basin with metal base, in lacquered
shiny resin. Fixing kit and trap included suitable for
art. 5234 (white and colours).

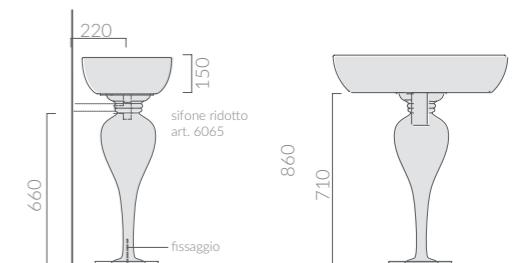
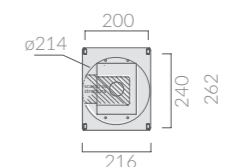



62_{cm} STRUTTURA PORTALAVABO Structure for basin

Art.		Kg	Pz.pallet	Ind.Price
5550AB	bianco white	21		182555.00
5550ANE	nero lucido glossy black	21		182555.00

Struttura portlavabo in resina, laccata lucida con basamento in metallo. Completo di fissaggio per lavabo e kit di scarico dell'acqua. Abbinabile al lavabo art. 9863 (bianco e nelle finiture colorate).

Structure for basin with metal base, in lacquered shiny resin. Fixing kit and trap included suitable for art. 9863 (white and colours).

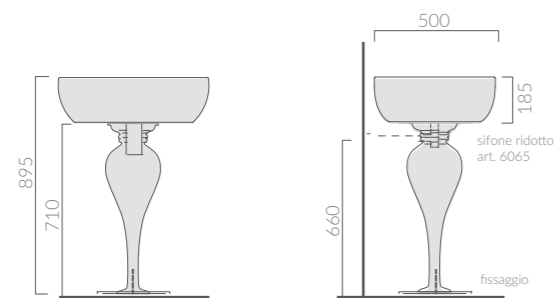
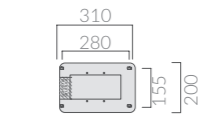

70_{cm} LAVABO Washbasin

Art.		Kg	Pz.pallet	Ind.Price
5234	bianco white	12,5	18	43355.00
5234AR	ardesia slate-grey	12,5	18	68150.00
5234TR	travertino travertine	12,5	18	68150.00

Lavabo ciotola cm 70x37xh15. Per rubinetteria a parete o su piano. Installazione da appoggio.
Bowl washbasin 70x37xh15 cm. Arranged for wall tap or on a countertop. Laid-on installation.

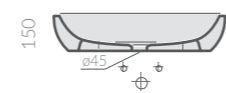
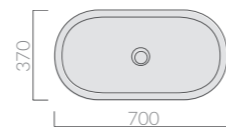

73 LAVABO Washbasin

Art.	Kg	Pz.pallet	Ind.Price
6018	10	21	32625.00

Lavabo Macchia da appoggio cm 73x38,5. Fissaggio incluso.
Macchia countertop washbasin cm 73x38,5. Fixing kit included.

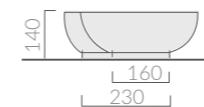
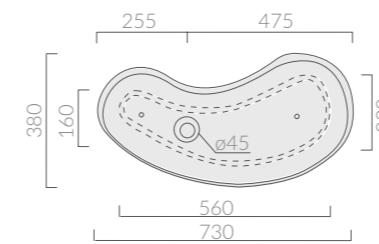

62 LAVABO Washbasin

Art.		Kg	Pz.pallet	Ind.Price
9863OR	oro/bianco gold/white	16	12	92510.00
9863PL	platino/bianco platinum/white	16	12	92510.00
9863NO	oro/nero gold/black	16	12	114260.00
9863NB	nero/bianco black/white	16	12	73950.00

Lavabo ciotola da appoggio 62x50xh18 cm. Per rubinetteria a parete o su piano. Countertop washbasin 62x50xh18 cm arranged for wall tap or on a countertop.

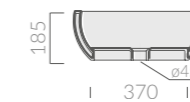
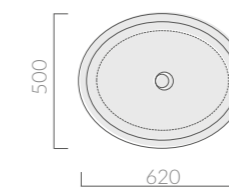



170x70

Art.		Kg	Pz.pallet	Ind.Price
1108BI	bianco white	59,5		106430.00
1108GR	grigio grey	59,5		106430.00
1108NE	nero black	59,5		106430.00

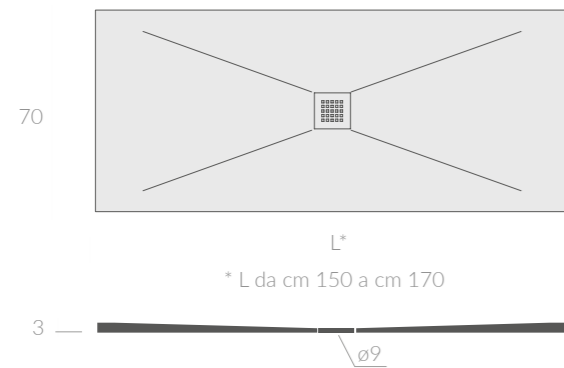

170

ETHOS VASCA Ethos bath-tub

Art.		Kg	Pz.pallet	Ind.Price
8497CR	nero black	60	1	501700.00

Vasca in vetroresina, esterno nero, completa di colonna di scarico, staffe di fissaggio e piedi cromati.
Fiberglass bath-tub, black outside, with chromed draining column, siphon, fixing brackets and chromed feet.

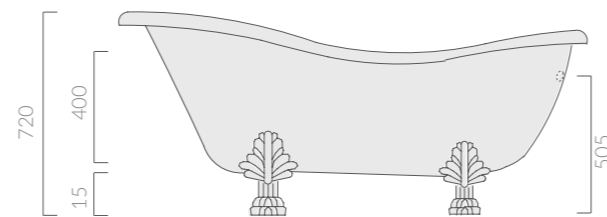

60_{cm}

SPECCHIERA Mirror

Art.		Kg	Pz.pallet	Ind.price
6125BI	bianco white	15		80330.00
6125NE	nero black	15		89900.00

Specchio ø60 cm con cornice di ottone verniciato e cinghie di cuoio.
Mirror ø60 cm with frame in lacquered brass and leather straps.

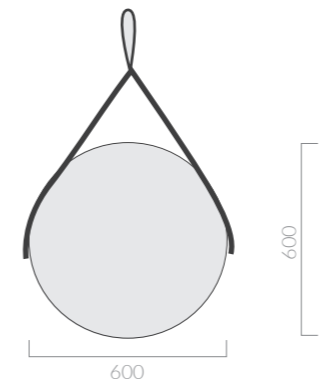

TABULAE

MENSOLA IN CERAMICA
/ Ceramic shelf



COLORI / Colors

-  bianco / white
-  bianco mat / matt white
-  nero mat / matt black
-  sabbia / sand
-  ottanio / petrol blue



SPESSORI SOTTILI
/ Thicknesses

COLORI E FINITURE

/ colors and finishes

FINITURE STRUTTURE
/ Structure finishes



oro chiaro
/ light gold



rame
/ copper



nero mat
/ matt black

COLORI CERAMICA
/ Ceramic colors



bianco mat
/ matt white



bianco
/ white



nero mat
/ matt black



ottanio
/ petrol blue



sabbia
/ sand

COLORI MOBILI
/ Furniture colors

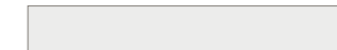

bianco opaco
/ matt white
art. 0000 BM



moka opaco
/ matt dark brown
art. 0000 MK



nero opaco
/ matt black
art. 0000 NM



fango opaco
/ matt mud
art. 0000 FA



sabbia opaco
/ matt sand
art. 0000 SA

FINITURE MOBILI
/ Furniture finishes



legno quercia
/ oakwood

CONDIZIONI GENERALI DI VENDITA

PREZZI FRANCO FABBRICA IVA ESCLUSA

SUI PREZZI DEL PRESENTE LISTINO VIENE ADDEBITATO IL 3% A PARZIALE RECUPERO DELLE SPESE DI IMBALLO; IL TRASPORTO VIENE ADDEBITATO AL COSTO. LE COMPOSIZIONI DEL PALLET SONO EVIDENZIATE NEL LISTINO EVENTUALI VARIAZIONI DELLE COMPOSIZIONI STANDARD, COMPORTERANNO UN ADDEBITO ULTERIORE NELL'IMBALLO AL COSTO.

- 1) ORDINI.** L'ACCETTAZIONE DELL'ORDINE È SEMPRE SUBORDINATA ALL'APPROVAZIONE DELLA VENDITRICE, CHE PUÒ DARE CONFERMA SCRITTA ALL'ACQUIRENTE.
- 2) CONSEGNA.** LA CONSEGNA AVVIENE SEMPRE PRESSO IL NS. STABILIMENTO DI CORCHIANO, QUALUNQUE SIA LA DESTINAZIONE E LE CONDIZIONI PATTUITE. GLI ORDINI POSSONO ESSERE EVASI ANCHE FRAZIONATAMENTE. LA MERCE VIAGGIA SEMPRE A TOTALE RISCHIO E PERICOLO DEL COMMITTENTE ANCHE SE CONVENUTO IL TRASPORTO FRANCO DESTINO.
- 3) TRASPORTO.** IL TRASPORTO È A CARICO DEL COMMITTENTE. LE SPEDIZIONI PERTANTO AVVENGONO PER INCARICO E CONTO DEL COMMITTENTE, IL QUALE IN CASO DI AVARIE-ROTTURE-AMMANCHI DEVE IMMEDIATAMENTE NOTIFICARLO A MEZZO VETTORE ALLA NS. SOCIETÀ AL MOMENTO DELLA CONSEGNA. LA MERCE CONSEGNATA RIMANE DI RISERVATO DOMINIO DELLA VENDITRICE FINO ALL'AVVENUTO PAGAMENTO.
- 4) TERMINI DI CONSEGNA.** I TERMINI DI CONSEGNA SI INTENDONO SEMPRE INDICATIVI ED IN RELAZIONE ALLE POSSIBILITÀ DEL MOMENTO. NON SI ASSUME ALCUNA RESPONSABILITÀ PER RITARDI O MANCATE CONSEGNE PER FATTI ED ATTI INDIPENDENTI DALLA NS. VOLONTÀ.
- 5) PREZZI.** POSSONO ESSERE VARIATI IN OGNI MOMENTO SENZA PREAVVISO E SOSTITUITI CON QUELLI IN VIGORE AL MOMENTO DELLA CONSEGNA DELLA MERCE, ANCHE SE RIFERITI AD ORDINI PRECEDENTI.
- 6) PAGAMENTI.** I PAGAMENTI SONO VALIDI SOLO SE EFFETTUATI CON I DIVERSI MEZZI, PRESSO LA SEDE SOCIALE DELL'AZIENDA E CON APPOSIZIONE DI REGOLARE QUIETANZA. QUALSIASI ALTRO PAGAMENTO RESTA A TOTALE RISCHIO DEL COMMITTENTE. I PAGAMENTI NON EFFETTUATI ALLE SCADENZE PATTUITE DANNO DIRITTO ALLA NS. SOCIETÀ DI SOSPENDERE LE FORNITURE IN CORSO. IN CASO DI RITARDO NEI PAGAMENTI CHIEDERÀ L'IMPORTO MAGGIORATO DEGLI INTERESSI DOVUTI CON RIFERIMENTO AL TASSO BANCARIO CORRENTE MAGGIORATO DI 2 PUNTI.
- 7) IMBALLO.** L'IMBALLAGGIO VIENE EFFETTUATO IN PALLETS E RETRAIBILE. EVENTUALI ALTRE FORME, DA CONCORDARE, COMPORTANO ULTERIORI ADDEBITI IN FATTURA, AL COSTO.
- 8) RECLAMI.** IN CASO DI ERRORI O DIFETTI DI FABBRICAZIONE IL COMPRATORE DEVE PRESENTARE ALLA NS. SOCIETÀ REGOLARE RILIEVO CON LETTERA RACCOMANDATA ENTRO 8 GG. DAL RICEVIMENTO DELLA FATTURA. IN CASO DI RICONOSCIMENTO DEI DIFETTI, LA NS. SOCIETÀ LIMITA LA SUA DIRETTA RESPONSABILITÀ AL DECLASSAMENTO O ALLA RESTITUZIONE DEI PEZZI RITENUTI NON IDONEI. NESSUNA ALTRA RESPONSABILITÀ NÈ DIRETTA NÈ INDIRETTA PUÒ PERTANTO ADDOSSARSI LA NS. SOCIETÀ: IL MATERIALE CONTESTATO NON DÀ DIRITTO ALLA SOSPENSIONE DEI PAGAMENTI.
- 9) MISURE E COLORI.** LE CARATTERISTICHE SONO INDICATE A PURO TITOLO INFORMATIVO, E SONO COMUNQUE SOGGETTE ALLA TOLLERANZA D'USO. GLI ARTICOLI PRODOTTI POSSONO ESSERE MODIFICATI O SOPPRESSI IN QUALSIASI MOMENTO SENZA PREAVVISO.
- 10) FORO.** PER QUALSIASI CONTESTAZIONE IL FORO COMPETENTE È SEMPRE QUELLO DI VITERBO, ANCHE SE IL CONTRATTO È STIPULATO ALTROVE.
- 11) LE PRESENTI CONDIZIONI GENERALI SI INTENDONO TOTALMENTE ACCETTATE DAL COMMITTENTE DAL MOMENTO DEL CONFERIMENTO DELL'ORDINE, O CON IL RITIRO DEI PRODOTTI.**

Spett.le Cliente,

a tutela del marchio e della nostre politiche commerciali, siamo a rimetterVi le condizioni alle quali attenersi, per poter effettuare la vendita dei nostri prodotti, tramite il canale Internet (e-commerce)

CONDIZIONI DI VENDITA IN " E-COMMERCE "

- A) i prodotti del catalogo Galassia potranno essere posti in vendita con uno sconto massimo, dal listino in vigore, del 35%, esclusa IVA, trasporti e costi accessori;
- B) le spese di trasporto, l'IVA e qualsiasi altro costo accessorio, dovranno essere disgiunti dal prezzo del nostro prodotto offerto, in modo tale da rendere trasparente ed inequivocabile, il prezzo di vendita;
- C) divieto di usare qualsiasi sistema di "asta al ribasso";
- D) potranno essere usate solo immagini ufficiali tratte dai nostri cataloghi, l'uso di altre immagini, dovrà essere autorizzato dalla GALASSIA SPA.

GENERAL SALE TERMS

EX-FACTORY PRICES - I.V.A. EXCLUDED

ON THE PRESENT PRICE-LIST, PRICES WILL BE INCREASED OF 3% AT PARTIAL RECOVERING OF PACKING COST; THE SHIPMENT WILL BE DEBITED AT REAL COST. THE COMPOSITION OF EACH PALLET WILL BE SPECIFIED IN THE PRICE LIST. IF MODIFIED AS REGARDS THE STANDARD ONE, AN INCREASE AT COST WILL BE REQUESTED.

- 1) ORDERS.** THE ACCEPTANCE OF THE ORDER WILL BE ALWAYS SUBMITTED TO THE APPROVAL OF THE VENDOR WHO CAN GIVE WRITTEN CONFIRMATION TO THE BUYER.
- 2) DELIVERY.** THE DELIVERY WILL BE EX-FACTORY AT OUR FACTORY-ADDRESS IN CORCHIANO, EVEN IF THE FINAL DESTINATION AND THE AGREED CONDITIONS ARE DIFFERENT. PARTIAL SHIPMENTS ARE ALLOWED. THE SAFETY OF THE GOODS WILL BE AT COMPLETE LIABILITY OF THE BUYER EVEN IF THE DELIVERY TERM IS AGREED FREE DESTINATION.
- 3) SHIPMENT.** THE SHIPMENT FREIGHT HAS TO BE PAID BY THE BUYER SO THE SHIPMENTS WILL BE PREVIOUSLY AGREED WITH HIM. IN CASE OF DAMAGES, BREAKAGES OR SHORTAGES OF THE GOODS, THE BUYER IS OBLIGED TO NOTIFY IT AT OUR SOCIETY BY CARRIER AS SOON AS THE GOODS HAVE BEEN DELIVERED. IN THIS CASE THE DELIVERED GOODS WILL REMAIN PROPERTY OF THE VENDOR UNTIL RECEIPT OF PAYMENT.
- 4) DELIVERY TERMS.** DELIVERY TERMS HAVE TO BE CONSIDERED INDICATIVE AND IN RELATION TO THE POSSIBILITIES OF THE PERIOD. WE DO NOT ASSUME ANY KIND OF LIABILITY FOR DELAYS OR FOR DRAWBACK OF DELIVERIES IF DUE TO FACTS AND ACTS INDIPENDENT OF OUR WILL.
- 5) PRICES.** PRICES CAN CHANGE WITHOUT NOTICE AND CAN BE REPLACED WITH PRICES EFFECTIVE AT THE PERIOD OF THE DELIVERY OF THE GOODS, EVEN IF THEY REFER TO PREVIOUS ORDERS.
- 6) PAYMENT TERMS.** PAYMENTS ARE VALID ONLY IF EFFECTED AND ADDRESSED TO THE SOCIAL ADDRESS OF THE FIRM AND BY REGULAR QUITTANCE. ANY OTHER PAYMENT IS AT COMPLETE RISK OF THE BUYER. THE PAYMENTS NOT EFFECTED ACCORDING TO THE AGREED PAYMENT TERMS OR IF EXPIRED, GIVE RIGHT TO THE SOCIETY TO STOP THE OUTSTANDING DELIVERIES. IF PAYMENT WILL BE RECEIVED ON DELAY, THE SELLER WILL DEMAND THE TOTAL AMOUNT TO BE PAID, INCREASED OF THE CURRENT INTEREST RATE EQUAL TO TWO POINTS.
- 7) PACKING.** THE PACKING IS EFFECTED ON PALLETS AND IT IS RESTRICTABLE. OTHER KIND OF PACKING MUST BE PREVIOUSLY AGREED. IF ANY CHARGE WILL BE NECESSARY, THIS WILL BE DEBITED ON THE COMMERCIAL INVOICE.
- 8) CLAIMS.** IN CASE OF ERRORS OR DEFECTS OF PRODUCTION, THE BUYER MUST PRESENT A CLAIM SENDING IT BY REGISTERED LETTER WITHIN 8 DAYS FROM THE RECEIPT OF THE INVOICE. IN CASE THE DEFECTS WILL BE CONFIRMED BY THE SELLER, THE FACTORY CAN EITHER DECLASS THE ITEMS OR CAN SUBSTITUTE THE NOT SALEABLE PIECES. ANY OTHER LIABILITY NEITHER INDIRECT NOR DIRECT CAN BE DEBITED TO OUR SOCIETY. THE CONTESTED GOODS DO NOT GIVE ANY RIGHT TO SUSPEND THE PAYMENTS.
- 9) SIZES AND COLOURS.** THE FEATURES OF THE ITEMS ARE INDICATED ONLY FOR INFORMATION AND ARE SUBJECT TO THE TOLERANCE DUE TO THE USE. THE PRODUCED ITEMS CAN BE MODIFIED OR ELIMINATED FROM PRODUCTION WITHOUT GIVING ANY KIND OF NOTICE TO THE BUYER
- 10) RELEVANT COURT.** ANY CONTROVERSY FALLS WITHIN THE COMPETENCE OF THE VITERBO COURT.
- 11) THE ABOVE-MENTIONED GENERAL SALE TERMS WILL BE CONSIDERED ENTIRELY ACCEPTED BY THE BUYER WHEN HE SUBSCRIBES THE ORDER OR WHEN THE PRODUCTS ARE COLLECTED.**

Commercial terms for sales in e-commerce

Dear Customer,

In order to protect the trademark and our commercial policy, herewith you can find the business terms and conditions to sell our products through the Web (e-commerce) Conditions of sale in "e-commerce"

- A) Galassia catalogue products can be sold with the maximum discount of the 35% (thirty-five per cent) from the RRP price list, excluding Vat, freight and additional costs.
- B) Freight costs, Vat and further costs, will need to be clearly separated from the offered product, so that the sale price is clear.
- C) It is not allowed to use any system of lowering the price.
- D) You can just use official pictures and images from our catalogues, any other uses have to be authorized by Galassia spa.

GALASSIA *Italy*

Zona Industriale loc. Pantalone
01030 Corchiano (VT) - Italy
T +39 0761 573134
F +39 0761 573458
info@ceramicagalassia.com

Filiale: Galassia Hispania s.a.u.
c/puerto rico n°4 - 28971
Griñon - Madrid (ES) - Spain
T +34 91.810.34.77
F +34 91.814.94.42
info@galassiahispania.com

www.ceramicagalassia.it

Ogni prodotto Galassia viene progettato e realizzato in Italia, secondo gli standard di qualità rispondenti alle norme 9001 ISO e 14001 ISO, monitorando e controllando ogni fase del processo produttivo e riducendo così l'impatto ambientale.

Each Galassia product is designed and made in Italy, according to the quality standard complying with Iso 9001 and 14001. Production cycle is supervised and controlled in order to reduce environmental issues.

Certified Quality System ISO 9001 - ISO 14001



**UNI EN ISO
9001:2015**



**UNI EN ISO
14001:2004**

Concept:
Antonio Pascale

Graphic:
Stefania Nicolosi
Federica Capoduri

Photos:
Antonio Pascale
Angelica Baldi
Centro Fotografico

Print:
Telligraf
Edizione n.1 / Luglio 2018

Ceramica Galassia si riserva il diritto di apportare ai propri prodotti, senza preavviso, qualsiasi modifica che ritenga opportuna.

Galassia SpA reserves the right to modify their products, if necessary, at any time without notice.

SHAPES
FOR
ARCHITECTURE

GALASSIA
Italy